

# MULTITEL

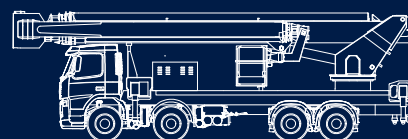

## SMX 225

Hauteur de travail env.	Max working height	Maximale Arbeitshöhe	Altezza max di lavoro	22,40 m
Hauteur plancher nacelle env.	Maximum platform height	Maximale Plattformhöhe	Altezza piano calpestio cestello	20,40 m
Déport maxi de travail env.	Max working outreach	Maximale seitliche Reichweite	Sbraccio max di lavoro	
<i>stab. complètement étendus</i>	<i>fully extended stabilizers</i>	<i>Ganz Ausgefahrene stützen</i>	<i>stab. completamente estesi</i>	8,50 m (200 kg) - 10,25 m (120 kg)
<i>stab. étendus partiellement</i>	<i>partially extended stabilizers</i>	<i>Partial Ausge Fahrene Stützen</i>	<i>stab. parzialmente estesi</i>	6,85 m (200 kg) - 8,25 m (120 kg)
Rotation de la tourelle	Turret rotation	Schwenkbereich	Rotazione torretta	360°
Rotation de la nacelle	Cage rotation	Hydraulische Korbdrehung	Rotazione idraulica del cestello	90°+ 90°
Sortie télescopique des bras.env	Boom telescopic amplitude	Teleskopausschub	Escursione telescopica dei bracci	4,60 + 5,46 m
Dimensions maxi nacelle	Max cage dimensions	Max Arbeitskorbabmessungen	Dimensioni max del cestello	1,40x0,70x1,10 m
Charge utile en nacelle	Safe working load on cage	Tragfähigkeit	Portata cestello	200/120 kg
Moteur thermique	Engine	Thermomotor	Motore termico	Kubota Z 602 - 10,9kW / 3200 rpm
Moteur électrique	Electric motor	E-Motor	Motore elettrico	2,2kW / 230V / 50Hz / 1500 rpm
Vitesse max de translation	Max translation speed	Max. Fahrgeschwindigkeit	Velocità max traslazione	1,4 km/h
Pente franchissable maxi	Max surmountable slope	Steigfähigkeit	Pendenza max superabile	14° / 25%
Poids total	Overall weight	Gesamtgewicht	Peso totale	2500 kg

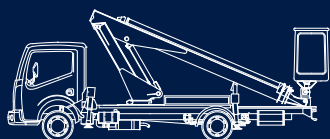

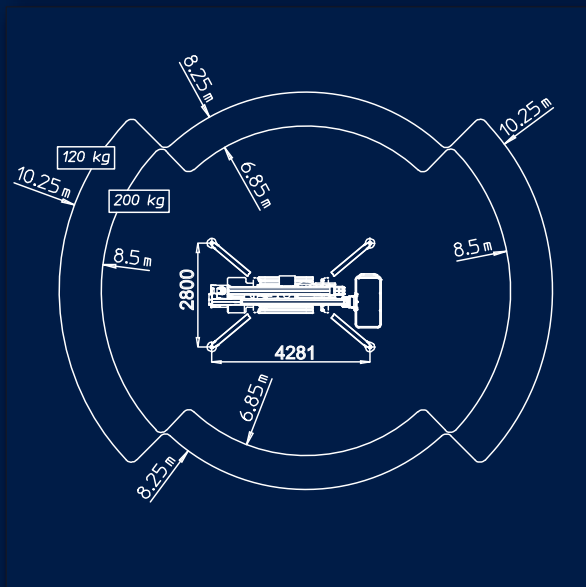
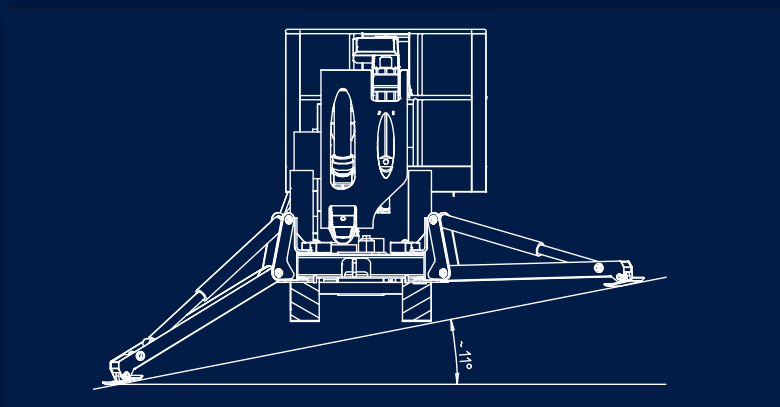
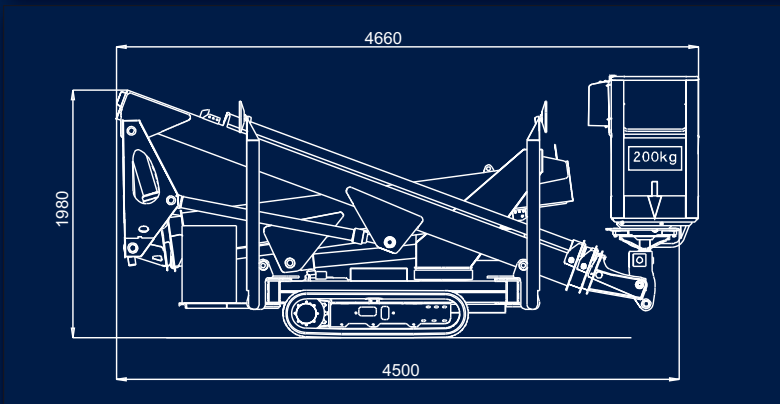
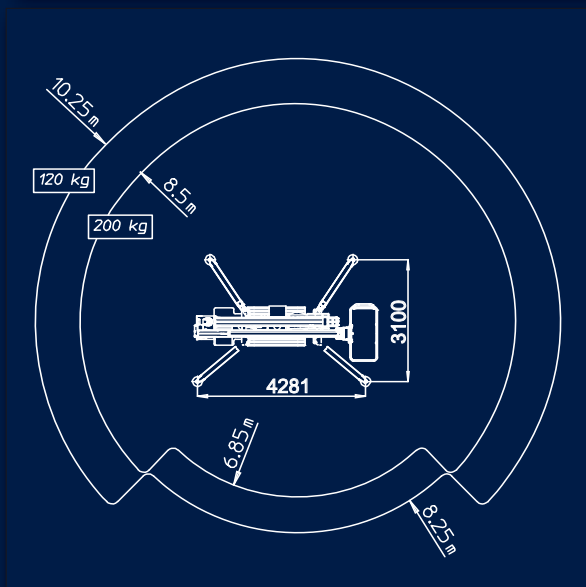
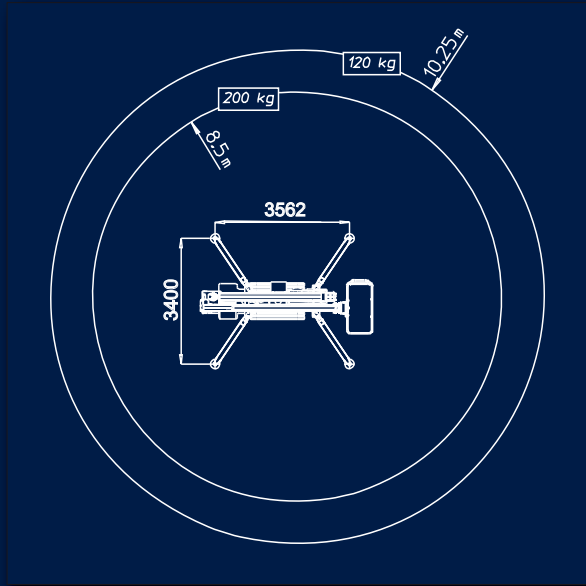
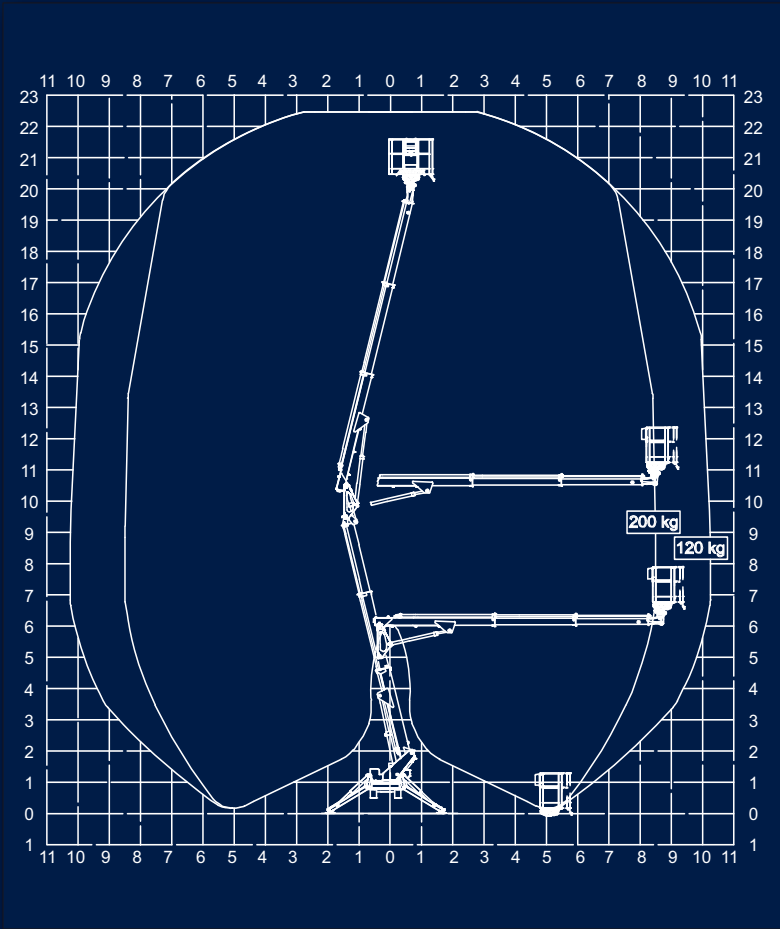

Et. 05/2010 Sous réserve de modification • Soggetto a modifiche senza preavviso Subject to change without notice • Technische Änderungen vorbehalten!

# MULTITEL

## HYDROLIFT

Hydrolift Entretien-Reparation-Vente

Z.I. de la Billonne, Lot N°4, 13170 Les Pennes, Mirabeau. Tél: 04 42 46 98 10 Fax: 04 42 46 98 14 [www.hydrolift.fr](http://www.hydrolift.fr)