

MULTITEL

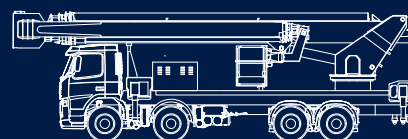

SHX190

Hauteur de travail env.	Max working height	Maximale Arbeitshöhe	Altezza max di lavoro	19,00 m
Hauteur plancher nacelle env.	Maximum platform height	Maximale Plattformhöhe	Altezza piano calpestio cestello	17,00 m
Déport maxi de travail env.	Max working outreach	Maximale seitliche Reichweite	Sbraccio max di lavoro	8,60 m
Rotation de la tourelle	Turret rotation	Schwenkbereich	Rotazione torretta	360°
Rotation de la nacelle	Cage rotation	Hydraulische Korbdrehung	Rotazione idraulica del cestello	60°+ 60°
Sortie télescopique des bras.env	Boom telescopic amplitude	Teleskopausschub	Escursione telescopica dei bracci	5,92 m
Dimensions maxi nacelle	Max cage dimensions	Max Arbeitskorbabmessungen	Dimensioni max del cestello	1,40x0,70x1,10 m
Charge utile en nacelle	Safe working load on cage	Tragfähigkeit	Portata cestello	200 kg
Moteur thermique	Engine	Thermomotor	Motore termico	Kubota Z 602 - 10,9kW / 3200 rpm
Moteur électrique	Electric motor	E-Motor	Motore elettrico	2,2kW / 230V / 50Hz / 1500 rpm
Vitesse max de translation	Max translation speed	Max. Fahrgeschwindigkeit	Velocità max traslazione	1,4 km/h
Pente franchissable maxi	Max surmountable slope	Steigfähigkeit	Pendenza max superabile	14° / 25%
Poids total	Overall weight	Gesamtgewicht	Peso totale	2300 kg

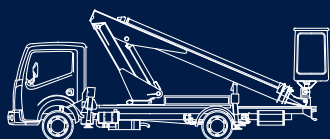

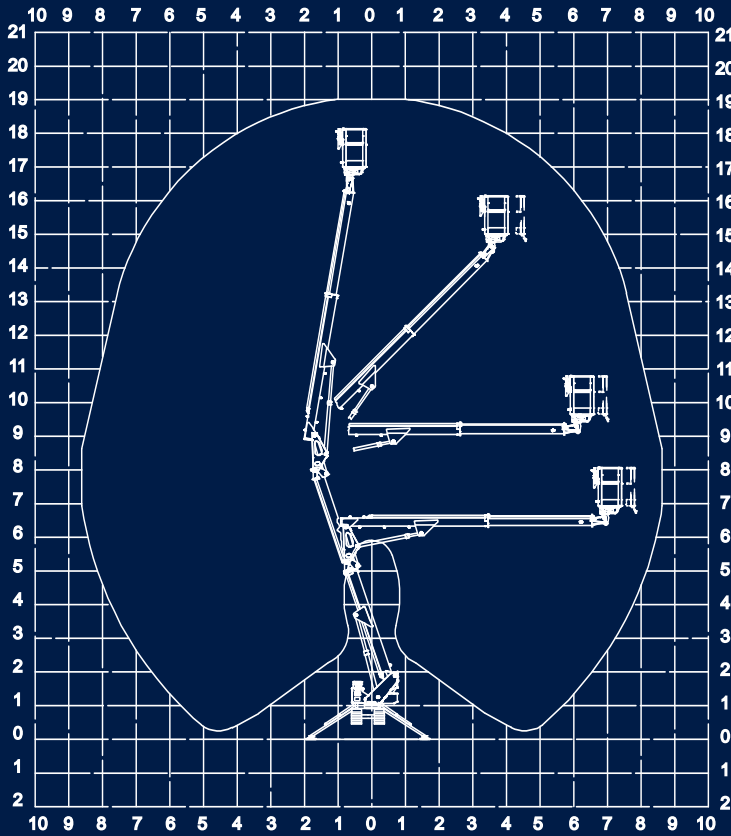

Ed. 09/2011 Sous réserve de modification • Soggetto a modifiche senza preavviso Subject to change without notice • Technische Änderungen vorbehalten!

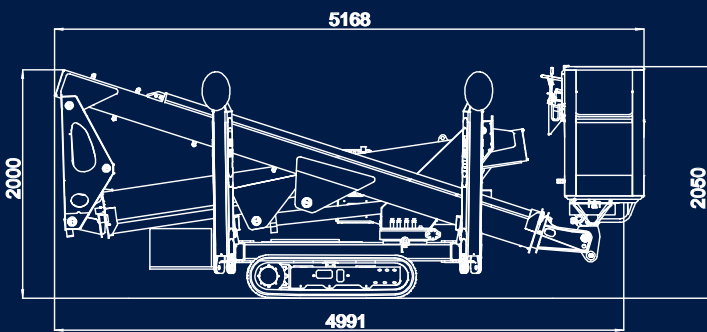

SHX190

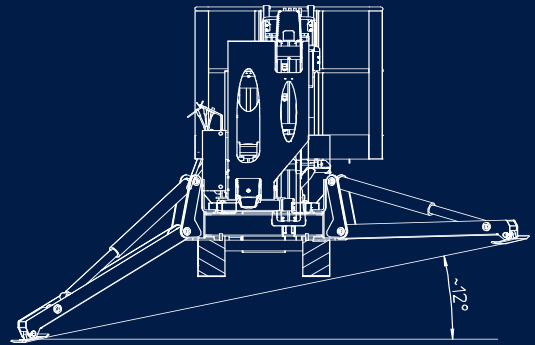
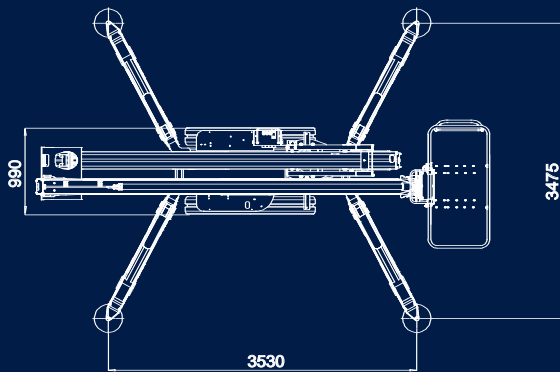

MULTITEL



Hydrolift Entretien-Reparation-Vente

Z.I. de la Billonne, Lot N°4, 13170 Les Pennes, Mirabeau. Tél: 04 42 46 98 10 Fax: 04 42 46 98 14 www.hydrolift.fr