

MULTITEL



MX270

- Commandes électro-hydrauliques proportionnelles avec la possibilité de réglage de la vitesse de tous les mouvements, aussi bien du sol que de la nacelle.
- Parallélogramme hydraulique de maintien à niveau nacelle.
- Sortie hydraulique des deux éléments télescopiques du bras.
- Chemins de câbles internes au bras.
- Clapets anti-retour sur tous les mouvements.
- Pompe manuelle pour manoeuvre d'urgence.
- Arrêt coup de poing en cas de panne.
- Démarrage et arrêt du moteur depuis la nacelle.
- Dispositif interdiction sortie télescopique et rotation tourelle avec bras à repos.

- Proportional electro-hydraulic controls from both control posts.
- Hydraulic cage levelling.
- Synchronous multi-stage telescope cylinders.
- Internal hose and cable ducts.
- Hydraulic check valves on all movements.
- Emergency hand pump.
- Emergency stop on both control stations.
- Engine start-stop on both control stations.
- Telescope retainer and turret rotation blocking in transport position.

- Elektro-Hydraulische Proportionalsteuerung mit Geschwindigkeitsregelung für alle Funktionen, von Korb- und Bodenbedienung.
- Hydraulische Korbnivellierung.
- Synchron-ausfahrende Mehrstufen Teleskop-Zylinder.
- Innenliegende Kabel- und Schlauchverlegung.
- Hydraulische Sperrventile auf jede Bewegung.
- Not-Handpumpe.
- Not-Stop an beide Steuerpulte.
- Fahrzeug Start-Stop an beide Steuerpulte.
- Teleskopausfahr- und Turmdreh Sperre in Transportstellung.

- Comando elettroidraulico proporzionale con regolazione della velocità di tutti i movimenti sia dal cestello che da terra.
- Parallelismo idrostatico del cestello.
- Uscita oleodinamica degli sfilii telescopici del braccio.
- Tubi e cavi installati all'interno del braccio.
- Valvole di blocco su ogni movimento.
- Pompa a mano di emergenza.
- Pulsante di arresto in caso di avaria.
- Avviamento e arresto del motore dal cestello.
- Dispositivo di interdizione uscita telescopico e rotazione torretta con braccio a riposo.

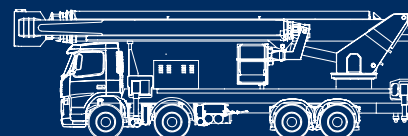
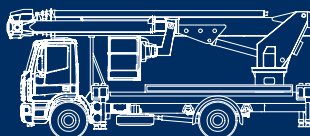
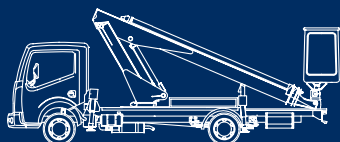



MX270

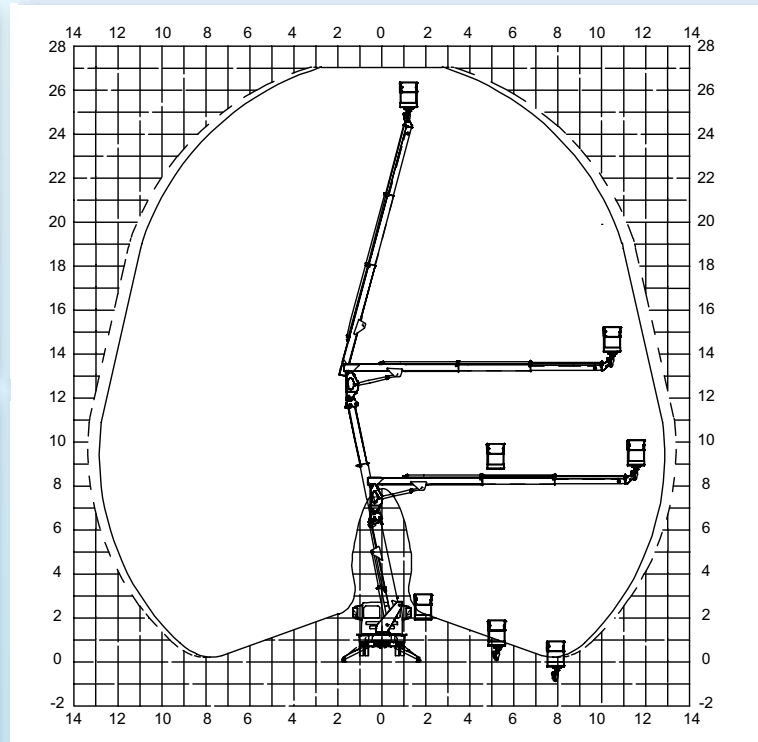
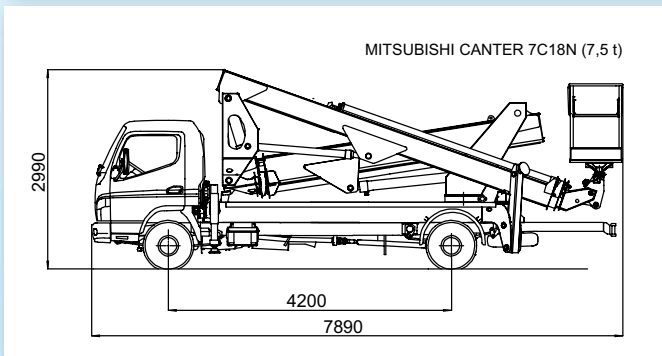
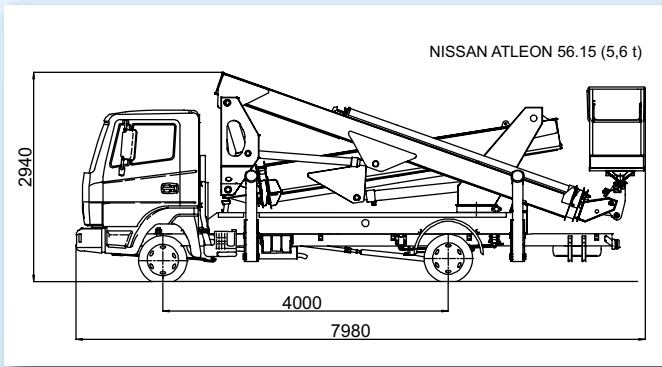

Hauteur de travail	Max working height	Maximale Arbeitshöhe	Altezza max di lavoro	27,30 m
Hauteur plancher nacelle	Maximum platform height	Maximale Plattformhöhe	Altezza piano calpestio cestello	25,30 m
Déport maxi de travail	Max working outreach	Maximale seitliche Reichweite	Sbraccio max di lavoro	12,80/13,30 m
Rotation de la tourelle	Turret rotation	Schwenkbereich	Rotazione torretta	360°
Rotation de la nacelle	Cage rotation	Hydraulische Korbdrehung	Rotazione idraulica del cestello	90° + 90°
Sortie télescopique des bras	Boom telescopic amplitude	Teleskopausschub	Escursione telescopica dei bracci	11,59 m
Dimensions maxi nacelle	Max cage dimensions	Max Arbeitskorbabmessungen	Dimensioni max del cestello	1,70 x 0,80 x 1,10 m
Charge utile en nacelle	Safe working load on cage	Tragfähigkeit	Portata cestello	225 kg
Dévers maxi admissible	Max admissible slope	Maximale zulässige Neigung	Pendenza ammissibile	1°

MULTITEL



HYDROLIFT

Hydrolift Entretien-Reparation-Vente

Z.I. de la Billonne, Lot N°4, 13170 Les Pennes, Mirabeau. Tél: 04 42 46 98 10 Fax: 04 42 46 98 14 www.hydrolift.fr